

SPJ | dikey tanklı domestik hidroforlar

domestic water boosters

0,8-10-15



TANIM / Definition

Ev, küçük apartman ve çiftlik gibi su ihtiyacı az olan birimler için tasarlanmıştır. Hidrofor tankı, beş yollu çekvalf, basınç şalteri, manometre ve 5 m kablolu seviye flatörü standarttır.

Manufactured for small apartment buildings and farms, which required little water. Expansion tank, five-way check valve, pressure switch, monometer and level float with 5m cable is included in standard delivery.

KULLANIM YERLERİ / Main applications

Kullanım suyu	Domestic water
Bahçe sulama	Garden watering
Proses suyu	Process water

TEKNİK ÖZELLİKLER / Technical information

Emme ağız çapı / Suction nozzle	: 1"
Basma ağız çapı / Discharge nozzle	: 1"
Debi / Flow rate [max.]	: 3 m ³ /h
Emme derinliği / Suction depth [max.]	: 9 m
Basma yüksekliği / Head [max.]	: 70 mSS
Motor devri / Speed [max.]	: 2900 d/d
Akışkan sıcaklığı / Fluid temperature [max.]	: 60 °C
Çalışma gerilimi / Operating voltage	: 220 V, 50 Hz / 380 V, 50 Hz

MALZEME ÖZELLİKLERİ / Material properties

Pompa Gövdesi / Casign	Motor Gövdesi / Motor casign	Çark / Impeller	Enjektör / Injector	Difüzör / Diffuser	Pompa Mili / Shaft	Mekanik Salmastra / Mechanical seal
Pik döküm / Cast Iron	Alüminyum / Aluminum	Noryl / 30% glass fiber reinforced Noryl	Noryl / 30% glass fiber reinforced Noryl	Noryl / 30% glass fiber reinforced Noryl	AlSI 304	Karbon - Seramik / Carbon - Ceramic

PERFORMANS TABLOSU / Performance Table

Hidrofor Tipi / Booster Type	Motor Gücü / Power		Q	Flow Rate (m ³ /h)										
	kW	HP		0	0.3	0.6	0.9	1.2	1.5	1.8	2.1	2.4	2.7	3
SPJ 0,8 M	0.6	0.85		47	42	38	34	31	28.5	26	24	22	21	19
SPJ 10 M	0.75	1		56	51	47	44	41	38	36	33.5	31.5	29.7	28
SPJ 15 M-T	1.1	1.5		70	66	62	58	54	51	48	45	42.5	40	38

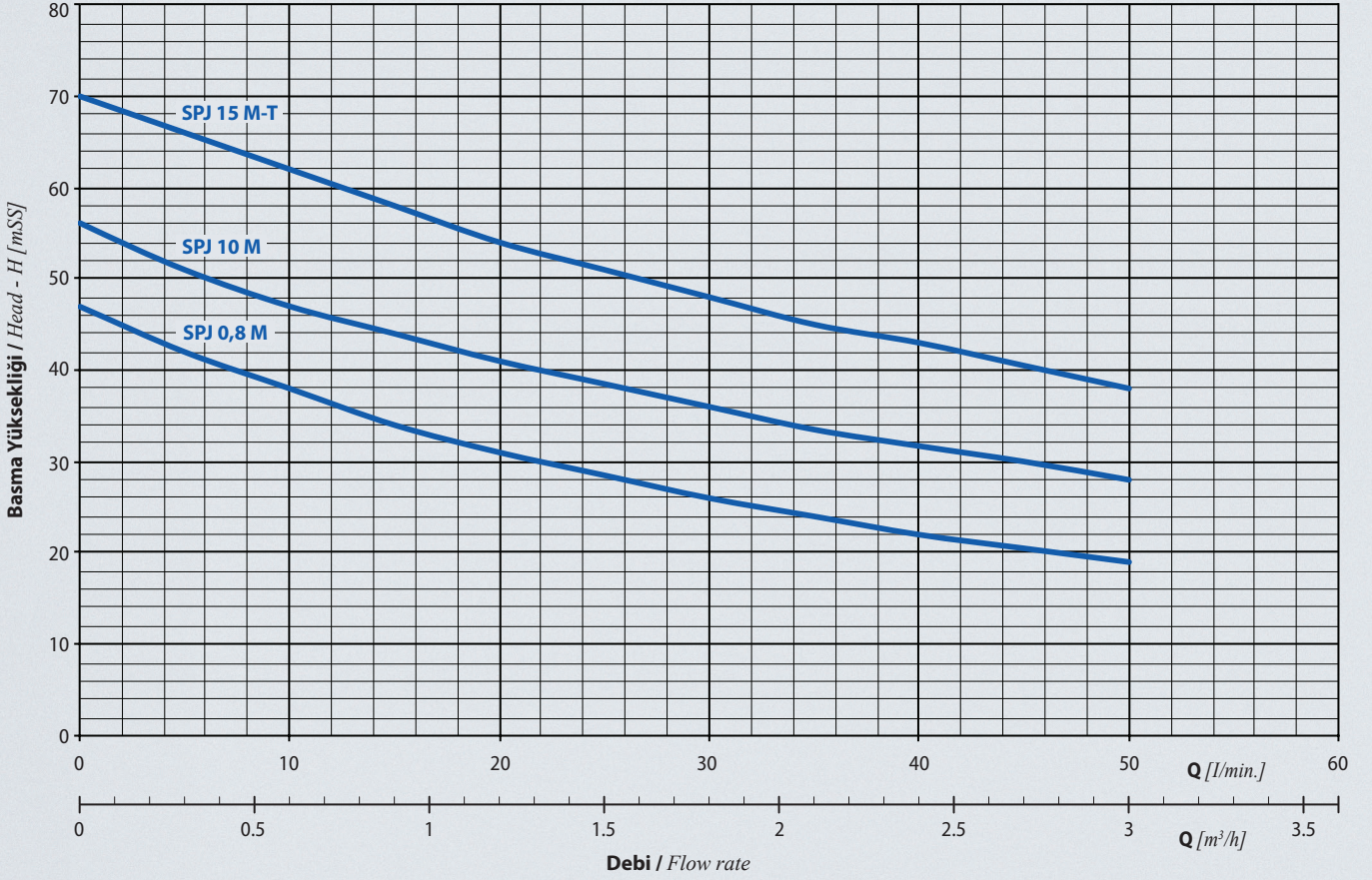

BOYUTLAR / Dimensions

SPJ dikey tanklı domestik hidroforlar
domestic water boosters

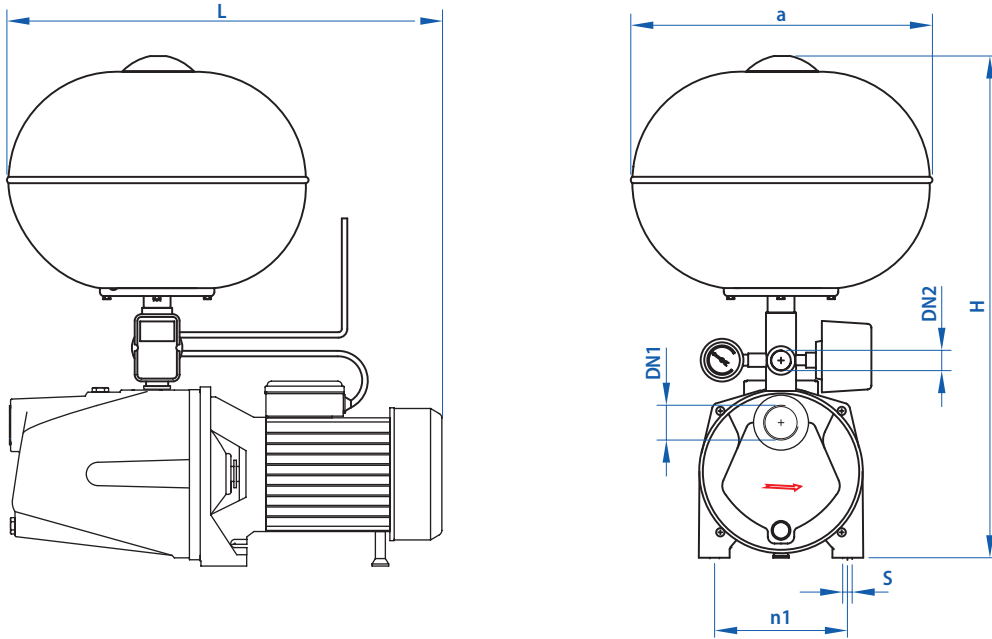

Hidrofor Tipi / Booster Type	Bağlantı Çapı / Connection		Tank Hacmi / Tank volume	Boyutlar / Dimensions [mm]					Ağırlık Weight [kg]
	Giriş / Suction	Çıkış / Discharge		a	øS	n1	H	L	
SPJ 0.8 M	1"	1"	24 L	354	9	128	760	452	16
SPJ 10 M	1"	1"	24 L	354	9	128	760	452	17
SPJ 15 M-T	1"	1"	24 L	354	9	143	786	469	18