

SPS 100 M

dikey tanklı domestik hidroforlar domestic water boosters



TANIM / Definition

Ev, küçük apartman ve çiftlik gibi su ihtiyacı az olan birimler için tasarlanmıştır. Hidrofor tankı, beş yollu çekvalf, basınç şalteri, manometre ve 5 m kablolu seviye flatörü standarttır.

Manufactured for small apartment buildings and farms, which required little water. Expansion tank, five-way check valve, pressure switch, monometer and level float with 5m cable is included in standard delivery.

KULLANIM YERLERİ / Main applications

Kullanım suyu	Domestic water
Bahçe sulama	Garden watering
Proses suyu	Process water

TEKNİK ÖZELLİKLER / Technical information

Emme ağız çapı / Suction nozzle	: 1"
Basma ağız çapı / Discharge nozzle	: 1"
Debi / Flow rate [max.]	: 6 m ³ /h
Emme derinliği / Suction depth [max.]	: 6 m
Basma yüksekliği / Head [max.]	: 34 mSS
Motor devri / Speed [max.]	: 2900 d/d
Akışkan sıcaklığı / Fluid temperature [max.]	: 60 °C
Çalışma gerilimi / Operating voltage	: 220 V, 50 Hz / 380 V, 50 Hz

MALZEME ÖZELLİKLERİ / Material properties

Pompa Gövdesi / Casign	Motor Gövdesi / Motor casign	Çark / Impeller	Pompa Mili / Shaft	Mekanik Salmastra / Mechanical seal
Pik döküm / Cast Iron	Alüminyum / Aluminum	Noryl / 30% glass fiber reinforced Noryl	AISI 304	Karbon - Seramik / Carbon - Ceramic

PERFORMANS TABLOSU / Performance Table

Pompa Tipi / Pump Type	Motor Gücü / Power		Q	m ³ /h	0	0.6	1.2	2.4	3.6	4.8	6
	kW	HP		L/min	0	10	20	40	60	80	100
SPS 100 M	1.1	1.5	Hm (mSS)	34	32	30	27	23	18	10	

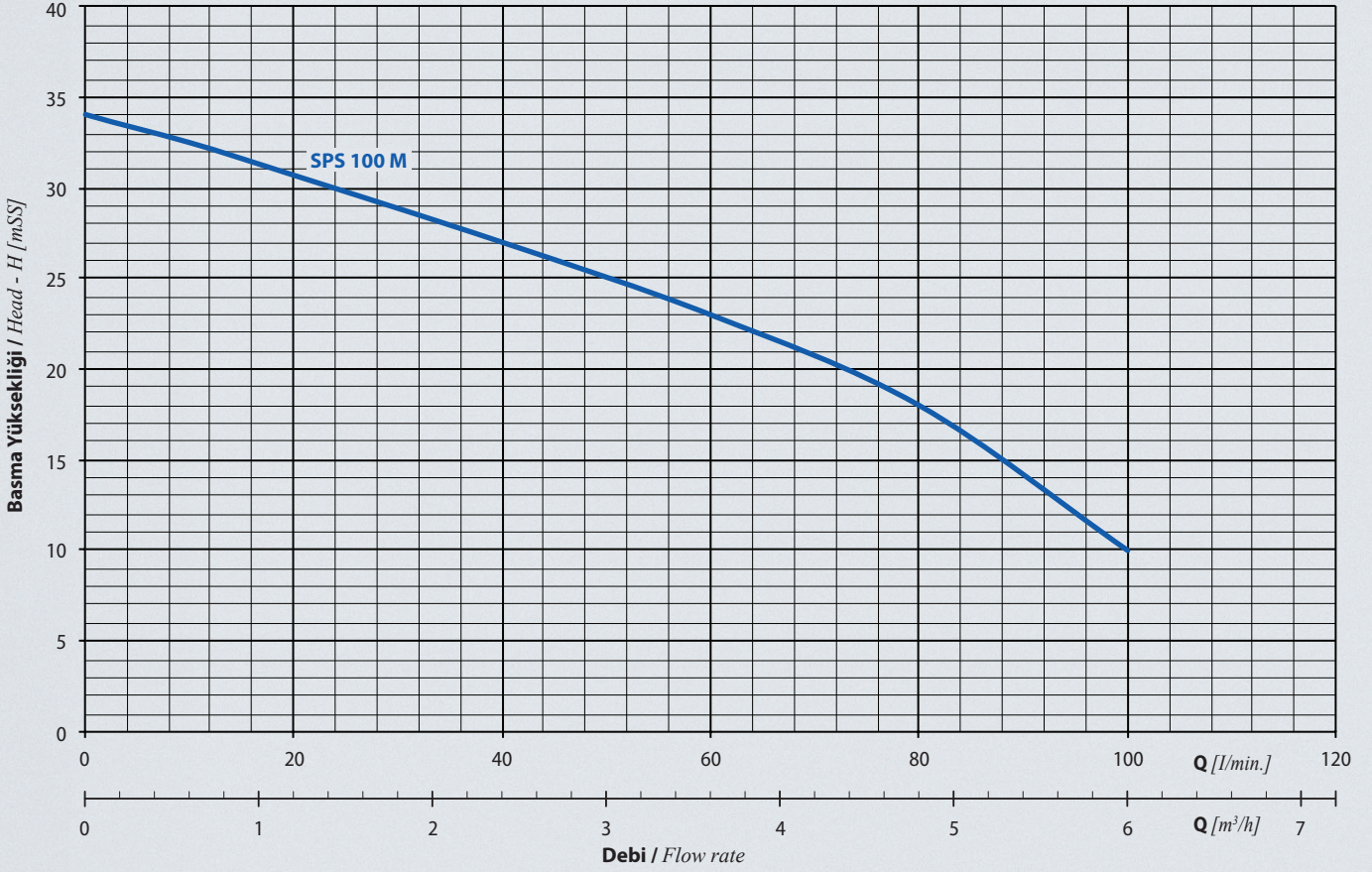

BOYUTLAR / Dimensions

SPS dikey tanklı domestik hidroforlar
domestic water boosters

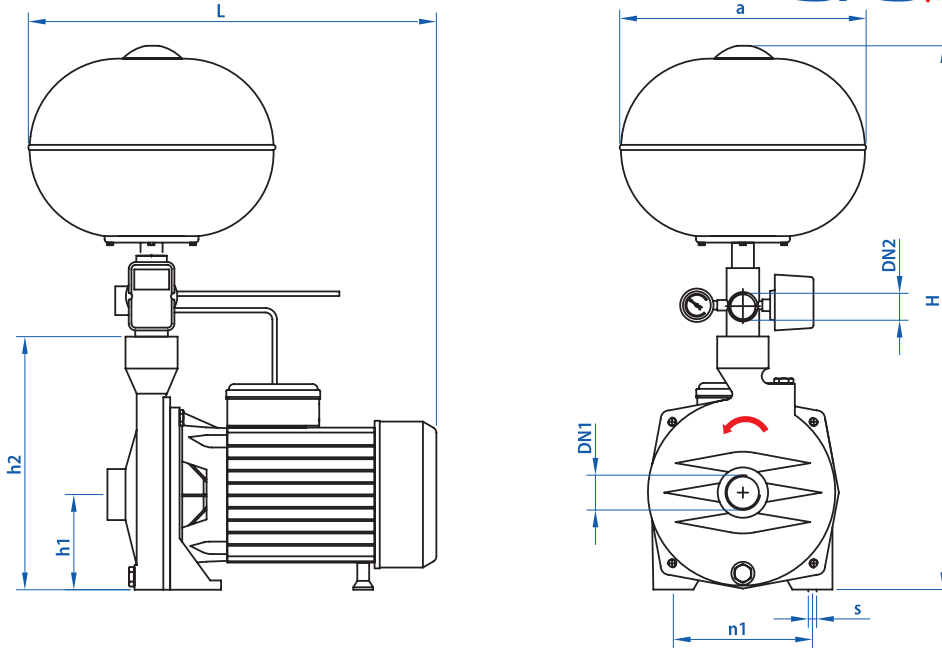

Hidrofor Tipi / Booster Type	Bağlantı Çapı / Connection		Tank Hacmi / Tank volume	Boyutlar / Dimensions [mm]						Ağırlık Weight [kg]	
	Giriş / Suction	Çıkış / Discharge		a	øS	H	L	h1	h2		n1
SPS 100 M	1"	1"	24 L	354	9	702	433	97	247	138	19,5